

## Overview

Since its debut in 1975, the M601 turboprop engine family has attained 17 million flight hours on more than 30 aircraft types.

The M601E-11 is the workhorse version of the proven M601 series engine for use in agricultural and utility aircraft applications. An available 751 SHP and a robust, durable design make it an excellent choice for aircraft operations in a variety of environments. With no hot section inspection requirement and an internal fuel slinger free of recurrent fuel nozzle maintenance, the M601E-11 provides distinct cost-of-ownership advantages over competing engines.

## Standard Engine Hardware

- Fuel control unit
- Fuel pump
- Ignition unit
- Oil filter impeding by-pass signaller
- Gas generator speed transmitter
- Prop speed transmitter
- ITT transmitter
- Torquemeter
- Oil temperature transmitter
- Engine mount body

## Accessories

- Starter/generator
- Propeller speed governor
- Propeller speed limiter
- Engine limiting unit
- Beta signaller switch
- Fuel filter with by-pass signaller

# M601E-11 Turboprop Engine

Proven power for turboprop aircraft

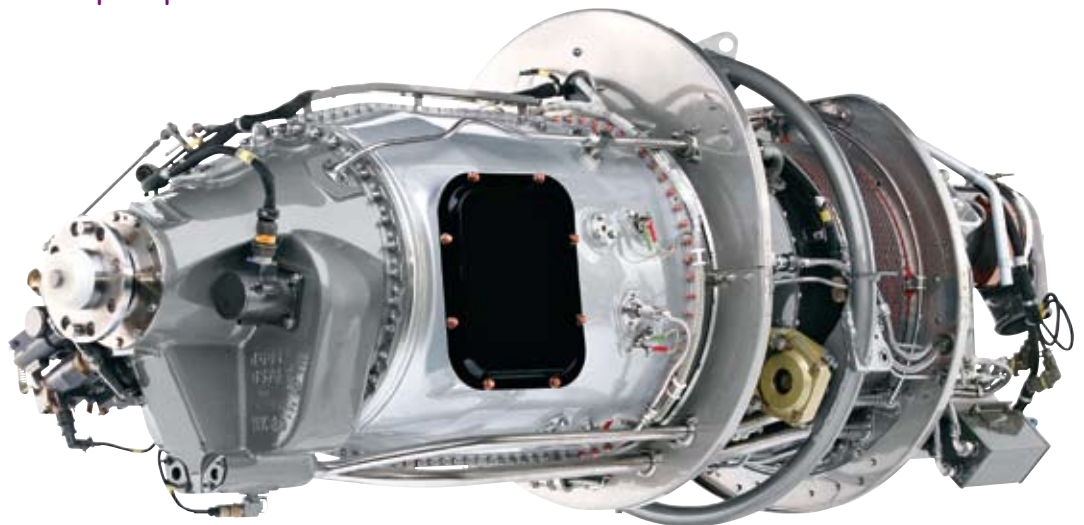

North America  
 Matt Gerus  
 T 513.552.2985  
 C 513.658.5096  
 matthew.gerus@ge.com

Europe  
 Michal Ptacnik  
 T +420 222 538 701  
 C +420 602 643 547  
 michal.ptacnik@ge.com

Beranoých 65  
 199 02 Praha 9  
 Czech Republic

geaviation.com

Specifications subject to change without notice.

© 2010 General Electric Company  
 All Rights Reserved.

GE Aviation Czech, s.r.o is a wholly owned  
 subsidiary of the General Electric Company.

## Specifications

Sea level - standard day	
Power Output	shp 751 eshp 798
ESFC	0.649
RPM	gas gen (98.6%) - 36,147 shaft output - 2,080
Propeller Rotation	ccw from rear
Weight	394 lbs
Pressure Ratio	6.65
Airflow	8.0 lb/s
Fuel	Jet A, Jet A-1
Oil	Mil-L 23699C
Electrical	27 VDC, 200 amp
Bleed Air	2.3% (max)
	Hours - 3,000
TBO	Cycles - 6,600
	Calendar - 8 years (total)

## Performance

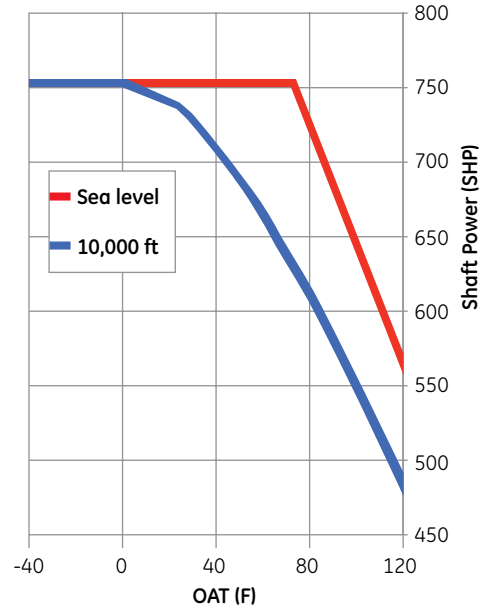

## Dimensions

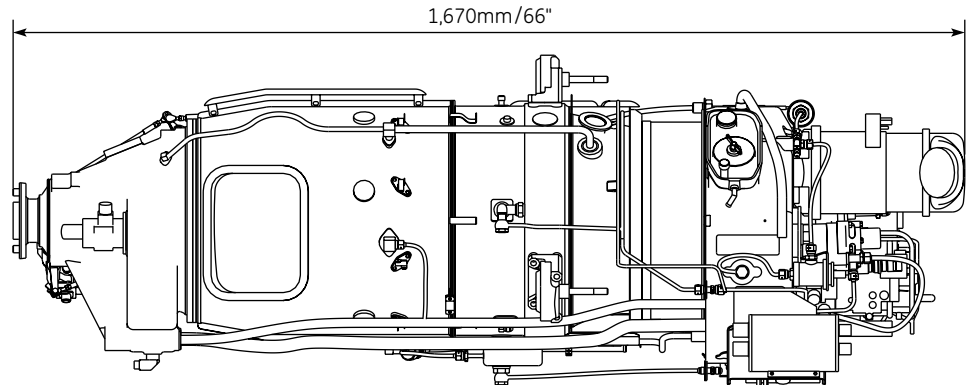
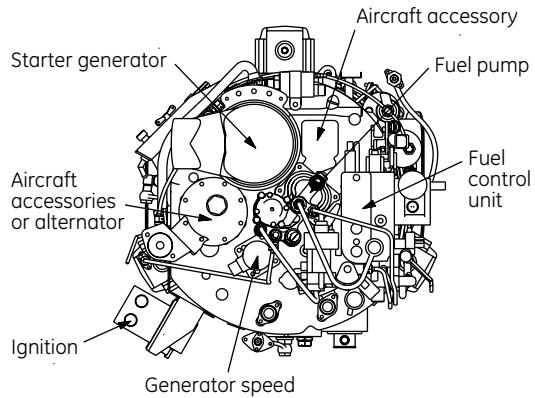
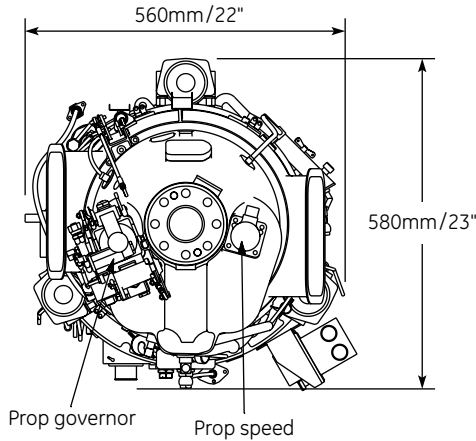

imagination at work